

INTERNATIONAL STANDARD

**ISO
13729**

Second edition
2020-08

Ships and marine technology — Ship's mooring and towing fittings — Closed chocks

*Navires et technologie maritime — Corps-morts et ferrures de
remorquage de navires — Chaumards fermés*



Reference number
ISO 13729:2020(E)

© ISO 2020

ISO 13729:2020(E)



COPYRIGHT PROTECTED DOCUMENT

© ISO 2020

All rights reserved. Unless otherwise specified, or required in the context of its implementation, no part of this publication may be reproduced or utilized otherwise in any form or by any means, electronic or mechanical, including photocopying, or posting on the internet or an intranet, without prior written permission. Permission can be requested from either ISO at the address below or ISO's member body in the country of the requester.

ISO copyright office
CP 401 • Ch. de Blandonnet 8
CH-1214 Vernier, Geneva
Phone: +41 22 749 01 11
Email: copyright@iso.org
Website: www.iso.org

Published in Switzerland

Contents

	Page
Foreword	iv
Introduction	v
1 Scope	1
2 Normative references	1
3 Terms and definitions	1
4 Classification	1
4.1 Type.....	1
4.2 Nominal sizes.....	1
5 Dimensions	2
6 Materials	2
7 Construction	2
8 Manufacturing and inspection	2
9 Marking	2
Annex A (normative) Basis for strength assessment of closed chocks	9
Bibliography	14

ISO 13729:2020(E)

Foreword

ISO (the International Organization for Standardization) is a worldwide federation of national standards bodies (ISO member bodies). The work of preparing International Standards is normally carried out through ISO technical committees. Each member body interested in a subject for which a technical committee has been established has the right to be represented on that committee. International organizations, governmental and non-governmental, in liaison with ISO, also take part in the work. ISO collaborates closely with the International Electrotechnical Commission (IEC) on all matters of electrotechnical standardization.

The procedures used to develop this document and those intended for its further maintenance are described in the ISO/IEC Directives, Part 1. In particular, the different approval criteria needed for the different types of ISO documents should be noted. This document was drafted in accordance with the editorial rules of the ISO/IEC Directives, Part 2 (see www.iso.org/directives).

Attention is drawn to the possibility that some of the elements of this document may be the subject of patent rights. ISO shall not be held responsible for identifying any or all such patent rights. Details of any patent rights identified during the development of the document will be in the Introduction and/or on the ISO list of patent declarations received (see www.iso.org/patents).

Any trade name used in this document is information given for the convenience of users and does not constitute an endorsement.

For an explanation of the voluntary nature of standards, the meaning of ISO specific terms and expressions related to conformity assessment, as well as information about ISO's adherence to the World Trade Organization (WTO) principles in the Technical Barriers to Trade (TBT), see www.iso.org/iso/foreword.html.

This document was prepared Technical Committee ISO/TC 8, *Ships and marine technology*, Subcommittee SC 4, *Outfitting and deck machinery*.

The committee responsible for this document is Technical Committee ISO/TC 8, *Ships and marine technology*, Subcommittee SC 4, *Outfitting and deck machinery*.

This second edition cancels and replaces the first edition (ISO 13729:2012), which has been technically revised.

The main changes compared to the previous edition are as follows:

- technical guidelines have been added in 7.2 and [7.3](#);
- the definition of SWL ([3.1](#)) has been reworded;
- the extension lines and dimension line in [Figures 1](#) and [2](#) have been amended;
- technical information on FEM has been added in [A.3.2](#).

Any feedback or questions on this document should be directed to the user's national standards body. A complete listing of these bodies can be found at www.iso.org/members.html.

Introduction

The closed chock is a type of ship's mooring and towing fitting installed on the shipside to lead the mooring and towing rope from the ship's inboard to outboard.

The closed chocks are normally adopted for ships which use wire ropes. The radius of chock surface was designed based on the bending ratio of rope through the chock of not less than twelve times the wire rope diameter.

Ships and marine technology — Ship's mooring and towing fittings — Closed chocks

1 Scope

This document specifies the types, nominal sizes, dimensions and materials, as well as construction, manufacturing and marking requirements, for closed chocks installed to lead the mooring and towing rope of a ship.

2 Normative references

The following documents are referred to in the text in such a way that some or all of their content constitutes requirements of this document. For dated references, only the edition cited applies. For undated references, the latest edition of the referenced document (including any amendments) applies.

IMO Circular MSC/Circ.1175, *Guidance on shipboard towing and mooring equipment*

3 Terms and definitions

For the purposes of this document, the following terms and definitions apply.

ISO and IEC maintain terminological databases for use in standardization at the following addresses:

- ISO Online browsing platform: available at <https://www.iso.org/obp>
- IEC Electropedia: available at <http://www.electropedia.org/>

3.1

safe working load

SWL

safe load limit (maximum permissible load) of the fittings used for mooring and towing

4 Classification

4.1 Type

The closed chock shall be classified by its installation site as belonging to one of the following types:

- a) Type A: deck-mounted closed chock;
- b) Type B: bulwark-mounted closed chock.

4.2 Nominal sizes

The nominal sizes, $L \times H \times D$, of closed chocks are denoted by reference to the width and height of the opening and the depth of the chock, in millimetres. For the closed chocks having the same size, the letter of the alphabet, i.e. A or B, is followed by the nominal size for the different SWL.

The nominal sizes are:

250 × 200 × 214, 300 × 250 × 286, 350 × 250 × 333, 400 × 250 × 381, 450 × 250 × 381, 500 × 250 × 381, 400 × 250 × 428, 450 × 250 × 428, 500 × 250 × 428, 500 × 400 × 428, 500 × 250 × 525A, 500 × 400 × 525A, 500 × 250 × 525B, 500 × 400 × 525B

ISO 13729:2020(E)

5 Dimensions

The closed chocks shall have dimensions and particulars in accordance with [Tables 1, 2, 3 and 4](#), and [Figures 1 and 2](#).

6 Materials

The following material shall be used for manufacturing the closed chocks:

- steel casting material, having a yield point of not less than 235 N/mm² or equivalent.

The carbon contents of the steel casting shall not be more than 0,23 % considering weldability.

7 Construction

7.1 The foundation of the closed chocks shall be determined by considering the actual load direction. The foundation and welding connections to the hull shall guarantee a reliable transmission of the maximum loading of the closed chocks to the hull construction without any plastic deformation or cracks.

7.2 The selection of ship's mooring fittings and mooring lines should take into account the diameter, D , of surfaces of mooring fittings that are in contact with the mooring line diameter, d , (D/d ratio) to reduce or mitigate bend loss of strength.

7.3 The tensile strength of mooring rope may be reduced depending on bend radius (D/d ratio) through the mooring fittings, in accordance with the rope manufacturer's guidelines.

8 Manufacturing and inspection

8.1 All surfaces of the closed chocks, including welded surfaces, shall be free from any visible flaws or imperfections.

8.2 All surfaces in contact with the ropes shall be free from surface roughness or irregularities likely to cause damage to the ropes by abrasion.

8.3 The closed chocks shall be coated externally with an anti-corrosion protective finish.

9 Marking

9.1 The SWL for the intended use of the closed chocks shall be noted in the towing and mooring plan available on board for the guidance of the shipmaster, as specified in IMO circular MSC/Circ.1175.

9.2 The actual SWL on board shall be determined by considering the foundation and under deck reinforcement, and it shall be marked on the towing and mooring plan. The actual SWL shall not be over the SWL indicated in this document.

9.3 The closed chocks shall be clearly marked with their SWL by weld bead or equivalent. The SWL shall be expressed in tonnes (symbol 't') and be placed so that it is not obscured during operation of the fitting.

EXAMPLE SWL XXX t

9.4 The SWL mark shall be provided on the foundation of the chock or on the deck.

9.5 The radii of edges and corners not shown in [Figure 1](#) shall be of minimum 25 mm.

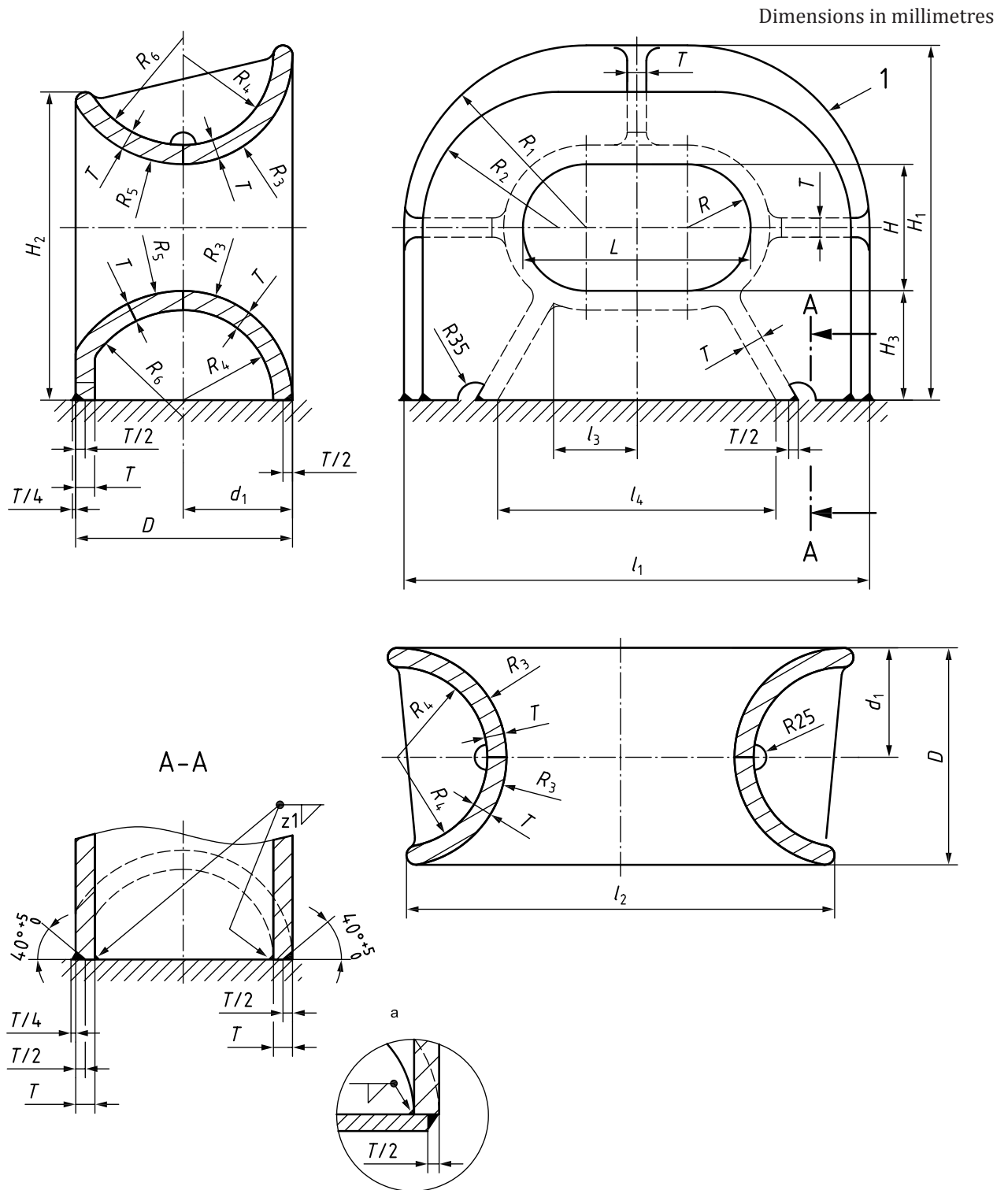

Key

- 1 closed chock
- a Alternative welding method.

Figure 1 — Type A — Deck-mounted closed chocks

ISO 13729:2020(E)

Table 1 — Dimensions of Type A — Deck-mounted closed chocks

Dimensions in millimetres

Nominal size <i>L × H × D</i>	<i>l</i> ₁	<i>l</i> ₂	<i>l</i> ₃	<i>l</i> ₄	<i>H</i> ₁	<i>H</i> ₂	<i>H</i> ₃	<i>R</i>	<i>R</i> ₁	<i>R</i> ₂	<i>R</i> ₃
250 × 200 × 214	488	453	76	265	427	368	108	100	219	160	108
300 × 250 × 286	614	565	89	330	551	481	144	125	282	212	144
350 × 250 × 333	716	660	114	403	601	525	168	125	308	232	168
400 × 250 × 381	820	754	139	475	652	553	192	125	335	236	192
450 × 250 × 381	870	804	164	524	652	553	192	125	335	236	192
500 × 250 × 381	920	854	189	574	652	553	192	125	335	236	192
400 × 250 × 428	870	796	139	500	701	609	216	125	360	268	216
450 × 250 × 428	920	846	164	550	701	609	216	125	360	268	216
500 × 250 × 428	970	896	189	600	701	609	216	125	360	268	216
500 × 400 × 428	970	896	176	600	851	759	216	200	435	343	216
500 × 250 × 525A	1 068	1 000	190	652	798	675	264	125	409	286	264
500 × 400 × 525A	1 068	1 000	193	652	948	825	264	200	484	361	264
500 × 250 × 525B	1 074	1 000	176	652	801	680	264	125	412	291	264
500 × 400 × 525B	1 074	1 000	179	652	951	830	264	200	487	366	264

Table 2 — Dimensions (continued) and SWL of Type A — Deck-mounted closed chocks

Dimensions in millimetres

Nominal size $L \times H \times D$	R_4	R_5	R_6	d_1	T	Welding leg length ^a z_1	SWL ^b		Wire rope diameter ^c (recommend- ed)	Calculated weight ^d kg
							kN	t		
250 × 200 × 214	86	150	128	108	22	6	226	23	18	73
300 × 250 × 286	118	180	154	144	26	6,5	422	43	24	142
350 × 250 × 333	138	200	170	168	30	7,5	549	56	28	222
400 × 250 × 381	156	250	214	192	36	9	687	70	32	310
450 × 250 × 381	156	250	214	192	36	9	706	72	32	322
500 × 250 × 381	156	250	214	192	36	9	765	78	32	337
400 × 250 × 428	178	250	212	216	38	9,5	883	90	36	434
450 × 250 × 428	178	250	212	216	38	9,5	912	93	36	452
500 × 250 × 428	178	250	212	216	38	9,5	932	95	36	472
500 × 400 × 428	178	250	212	216	38	9,5	893	91	36	528
500 × 250 × 525A	224	320	280	264	40	10	1 148	117	44	657
500 × 400 × 525A	224	320	280	264	40	10	1 158	118	44	724
500 × 250 × 525B	218	320	274	264	46	11,5	1 413	144	44	753
500 × 400 × 525B	218	320	274	264	46	11,5	1 383	141	44	825

^a The welding method may be changed based on the same welding volume/strength.

^b SWLs shown are for reference only. These are based on the loadings as mentioned in [Annex A](#).

The “SWL” which is marked on the fitting may be adjusted depending on the actual loading conditions of mooring rope under the agreement between the user and the manufacturer.

^c The wire rope diameter (recommended) is only for reference, based on a bending ratio of the rope through the chock of 12 times.

^d The calculated weight (mass) is for reference only.

ISO 13729:2020(E)

Dimensions in millimetres

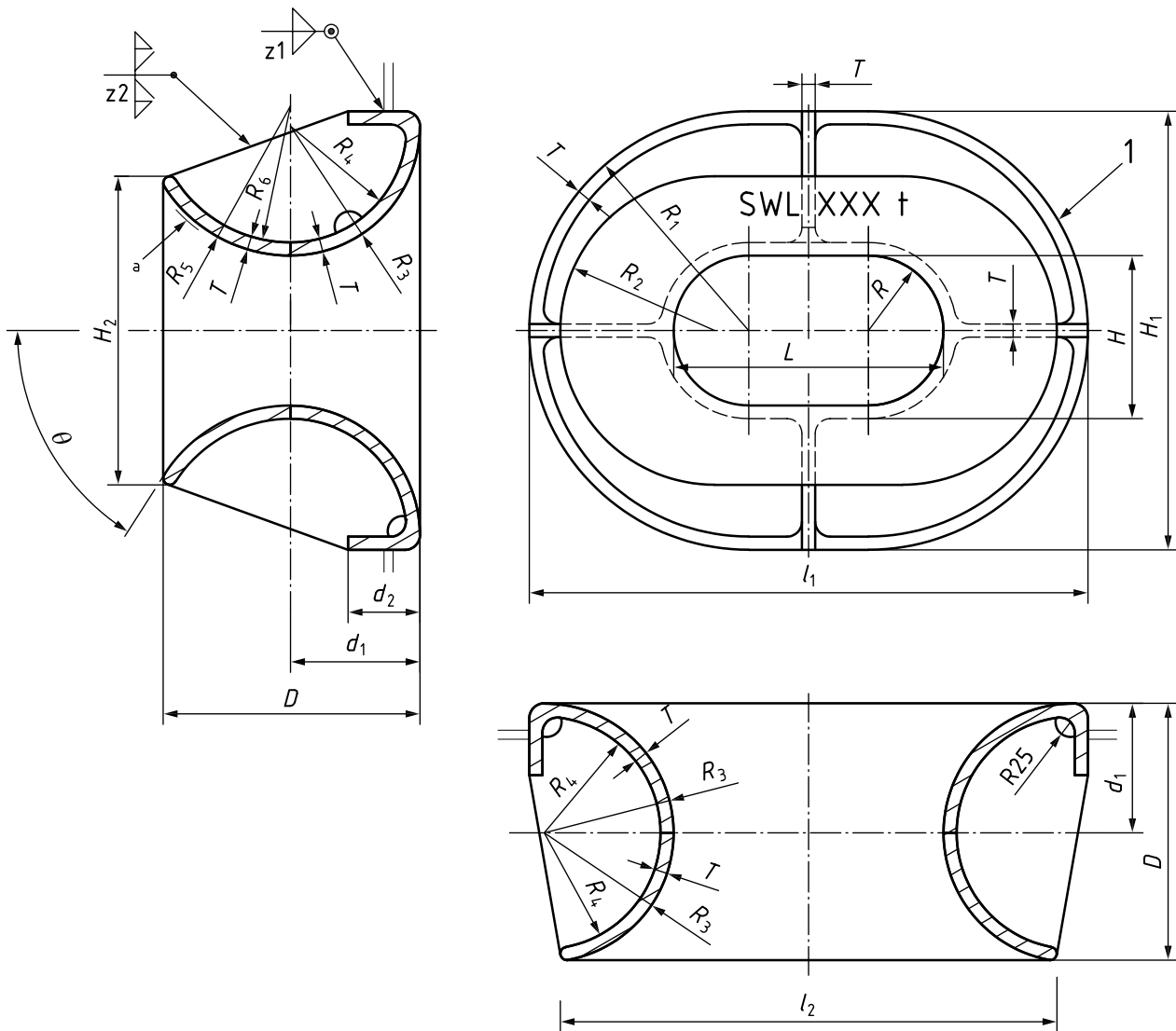

Key

- 1 closed chock
- θ° maximum available line leading angle limited by the end of curve surface (for reference)
- ^a SWL marking.

The SWL mark shall be provided on the chock or on the shell plate near the chock.

The radii of edges and corners not shown in this figure shall be of minimum 25 mm.

Figure 2 — Type B — Bulwark-mounted closed chocks

Table 3 — Dimensions of Type B — Bulwark-mounted closed chocks

Dimensions in millimetres

Nominal size <i>L × H × D</i>	<i>l</i> ₁	<i>l</i> ₂	<i>H</i> ₁	<i>H</i> ₂	<i>R</i>	<i>R</i> ₁	<i>R</i> ₂	<i>R</i> ₃	<i>R</i> ₄	<i>R</i> ₅
250 × 200 × 214	516	441	466	306	100	233	153	108	96	150
300 × 250 × 286	638	554	588	410	125	294	205	144	128	180
350 × 250 × 333	736	646	636	449	125	318	224,5	168	150	200
400 × 250 × 381	834	736	684	450	125	342	225	192	172	250
450 × 250 × 381	884	786	684	450	125	342	225	192	172	250
500 × 250 × 381	934	836	684	450	125	342	225	192	172	250
400 × 250 × 428	882	778	732	515	125	366	257,5	216	194	250
450 × 250 × 428	932	828	732	515	125	366	257,5	216	194	250
500 × 250 × 428	982	878	732	515	125	366	257,5	216	194	250
500 × 400 × 428	982	878	882	665	200	441	332,5	216	194	250
500 × 250 × 525A	1 078	976	828	551	125	414	275,5	264	240	320
500 × 400 × 525A	1 078	978	978	701	200	489	350,6	264	240	320
500 × 250 × 525B	1 078	976	828	554	125	414	277	264	238	320
500 × 400 × 525B	1 078	978	978	704	200	489	352	264	238	320

ISO 13729:2020(E)

Table 4 — Dimensions (continued) and SWL of Type B — Bulwark-mounted closed chocks

Dimensions in millimetres

Nominal size $L \times H \times D$	R_6	d_1	d_2	T	θ	Welding leg length ^a		SWL ^b		Wire rope diameter ^c (recommended)	Calculated weight ^d kg
						z_1	z_2	kN	t		
250 × 200 × 214	138	108	80	12	44°	6	5	226	23	18	49
300 × 250 × 286	164	144	100	16	44°	8	6,5	422	43	24	100
350 × 250 × 333	182	168	120	18	55°	9	7	549	56	28	141
400 × 250 × 381	230	192	120	20	47°	10	8	687	70	32	184
450 × 250 × 381	230	192	120	20	47°	10	8	706	72	32	194
500 × 250 × 381	230	192	120	20	47°	10	8	765	78	32	202
400 × 250 × 428	228	216	120	22	56°	10	9	883	90	36	264
450 × 250 × 428	228	216	120	22	56°	10	9	912	93	36	276
500 × 250 × 428	228	216	120	22	56°	10	9	932	95	36	288
500 × 400 × 428	228	216	120	22	56°	10	9	893	91	36	311
500 × 250 × 525A	296	264	120	24	53°	10	9,5	1 148	117	44	379
500 × 400 × 525A	296	264	120	24	53°	10	9,5	1 158	118	44	408
500 × 250 × 525B	294	264	120	26	53°	10	10,5	1 413	144	44	405
500 × 400 × 525B	294	264	120	26	53°	10	10,5	1 383	141	44	442

^a The welding method may be changed based on the same welding volume/strength.

^b The SWLs shown in this table are for reference only. These are based on the loadings as mentioned in [Annex A](#).

The “SWL” which is marked on the fitting may be adjusted depending on the actual loading conditions of mooring rope under the agreement between the user and the manufacturer.

^c The wire rope diameter (recommended) is only for reference, based on a bending ratio of the rope through the chock of 12 times.

^d The calculated weight (mass) is for reference only.

Annex A (normative)

Basis for strength assessment of closed chocks

A.1 General

The strength of the closed chocks was evaluated by finite element model analysis and determined based on the following design criteria.

A.2 Loading

The closed chocks shall be designed to withstand the horizontal and vertical load cases.

The horizontal and vertical loadings were considered individually, but both loadings were not considered simultaneously.

A.2.1 Case 1 — Horizontal loading

See Figure A.1.

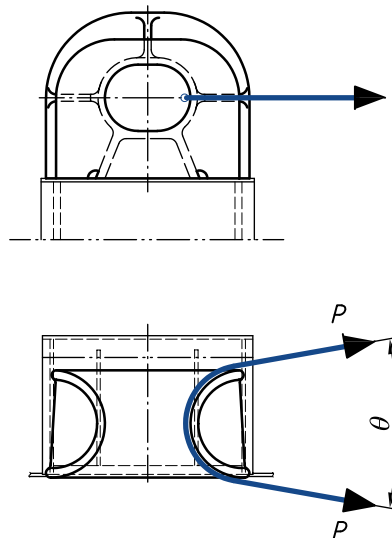

Key

P mooring force or towing force

NOTE The loads were considered for a rope deflected 180° ($\theta = 0^\circ$) through the closed chock.

Figure A.1 — Horizontal loading

A.2.2 Case 2 — Vertical loading

See [Figures A.2](#) and [A.3](#).

ISO 13729:2020(E)

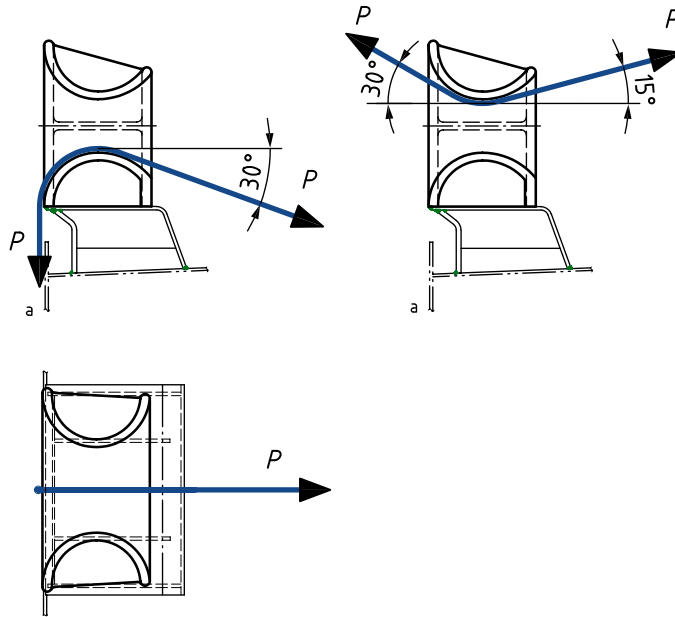

Key

P mooring force or towing force

a Ship side.

NOTE The loads were considered for a rope deflected as shown in this figure through the closed chock.

Vertical down side: outboard down 90°, inboard down 30°.

Vertical up side: outboard up 30°, inboard up 15°.

Figure A.2 — Vertical loading for Type A — Deck-mounted closed chocks

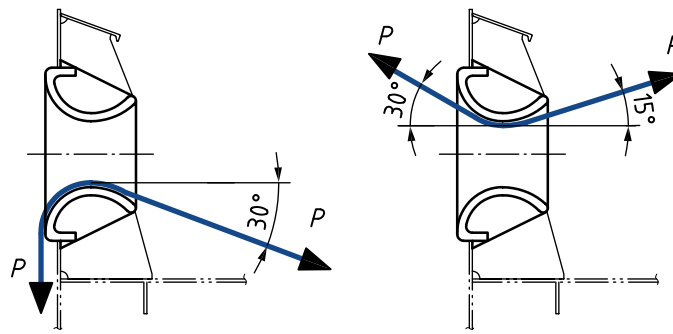

NOTE The loads were considered for a rope deflected as shown in [Figure A.3 a\)](#) through the closed chock.

Vertical down side: outboard down 90°, inboard down 30°.

Vertical up side: outboard up 30°, inboard up 15°.

a) Bulwark-mounted closed chocks without bulwark inclination

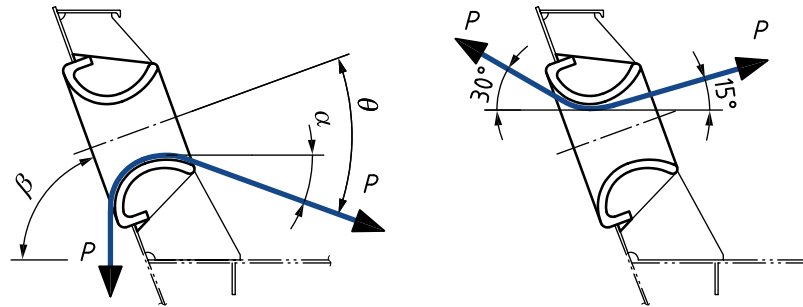

NOTE The loads were considered for a rope deflected as shown in [Figure A.3 b\)](#) through the closed chock.

Vertical down side: outboard down 90°, inboard down θ° is not to go over the figures in [Table 2](#).

Vertical up side: outboard up 30°, inboard up 15°.

b) Bulwark-mounted closed chocks with bulwark inclination

Key

P mooring force or towing force

α refer to the below table for instance at the design bulwark angle of $\beta = 60^\circ$.

ISO 13729:2020(E)

Nominal size $L \times H \times D$	(Maximum available angle) α
250 × 200 × 214	14°
300 × 250 × 286	14°
350 × 250 × 333	25°
400 × 250 × 381	17°
450 × 250 × 381	17°
500 × 250 × 381	17°
400 × 250 × 428	26°
450 × 250 × 428	26°
500 × 250 × 428	26°
500 × 400 × 428	26°
500 × 250 × 525A	23°
500 × 400 × 525A	23°
500 × 250 × 525B	23°
500 × 400 × 525B	23°

Figure A.3 — Vertical loading for Type B — Bulwark-mounted closed chock

A.3 Load and stress criterion

A.3.1 Stress criterion

Under the SWL, the combined stress is limited to 85 % of the yield stress of the material.

A.3.2 Analysis conditions for FEM

A.3.2.1 Boundary conditions

Boundary conditions are shown in [Table A.1](#) and [Figure A.4](#).

Table A.1 — Displacement and rotational degrees of freedom

Location	Dx	Dy	Dz	Rx	Ry	Rz
Model Bottom	Fix	Fix	Fix	Fix	Fix	Fix

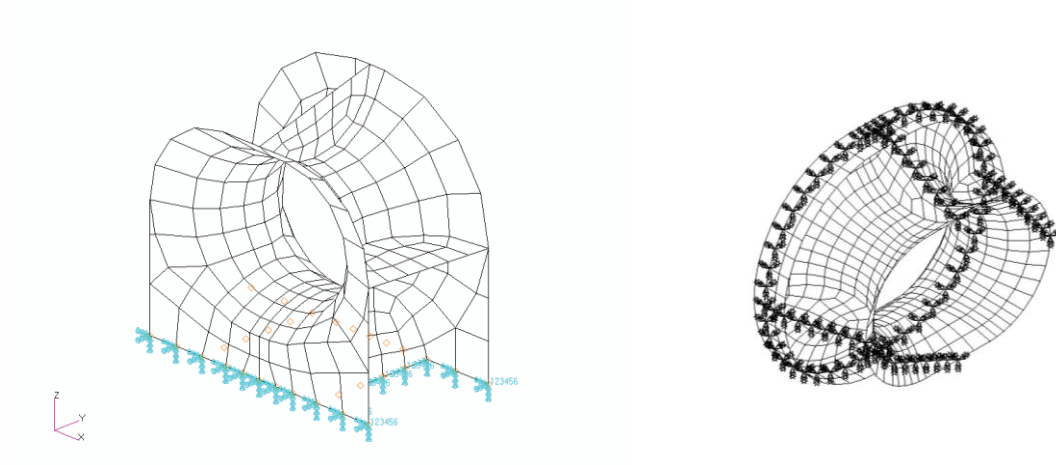

Figure A.4 — Displacement boundary condition

A.3.2.2 Mesh size

The closed chock was modelled based on 2 times the closed chock thickness.

A.3.2.3 Element

Closed chock – shell (2D).

A.4 Wear-down allowances and corrosion additions

The wear-down margin and corrosion margin were already included in the stress criterion specified in [A.3.1](#).

Bibliography

- [1] ISO 2408, *Steel wire ropes — Requirements*
- [2] ISO 4990, *Steel castings — General technical delivery requirements*
- [3] IACS UR A2, *Shipboard fittings and supporting hull structures associated with towing and mooring on conventional vessels*
- [4] OCIMF *Mooring Equipment Guidelines (MEG4)*

ISO 13729:2020(E)

ICS 47.020.50

Price based on 14 pages

© ISO 2020 – All rights reserved